

# AGS-SP-SB170-H

## DESCRIPTION

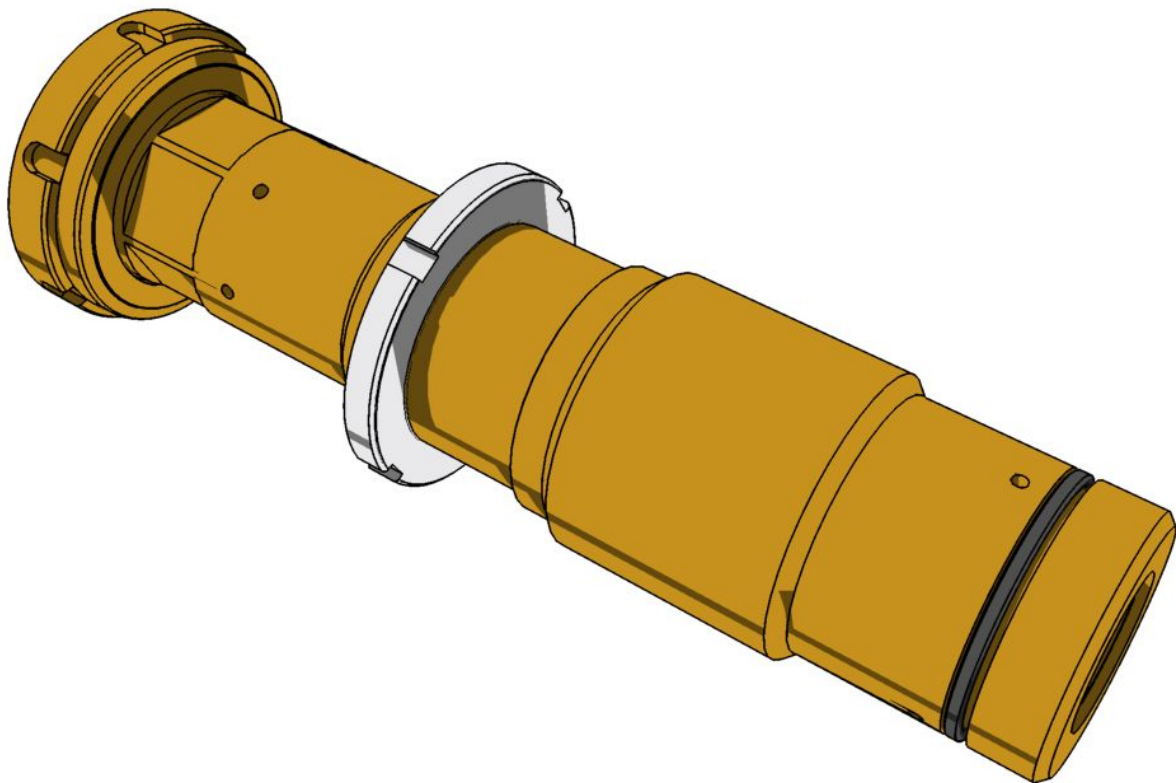

dametric 

# HOLDER PART OF THE AGS-SB170 SENSOR

## CONTENT

<b>1</b>	<b>GENERAL</b> .....	<b>2</b>
<b>2</b>	<b>SEALING</b> .....	<b>2</b>
<b>3</b>	<b>MOUNTING</b> .....	<b>2</b>
<b>4</b>	<b>OUTLINE DRAWING</b> .....	<b>3</b>
<b>5</b>	<b>METSO PAPER PART NO</b> .....	<b>3</b>
<b>6</b>	<b>CONTACTS</b> .....	<b>3</b>

### 1 GENERAL

The holder part of the AGS will mechanically fit the AGS-house to the refiner stator plate. There are several types of holders for different lengths, threads and sealing. The AGS-SP-SB170-H will fit the AGS in an Andritz SB-170 refiner.

The holder is included in a new AGS sensor but can also be bought as a spare part. The holder is replaced if the thread is damaged, if the sealing surface has become damaged or if the contact surface to the segment plate is damaged.

### 2 SEALING

The inside of the holder is used as a sealing surface to the sealing on the sensor tip. Special precaution must be used when cleaning the inside surfaces – use only a soft cloth.

### 3 MOUNTING

The holder is mounted directly to the AGS house (AGD-HM3) and the sensor tip must be mounted afterwards.

Use the ‘Holder exchange’ wizard on the Panel-PC to mount or dismount the holder and tip. The locking nut shall not be tightened yet; this to assure that the holder can be rotated when mounting the AGS sensor to the refiner.

Tight the locking nut when the AGS sensor is tightened toward the refiner plates.

## 4 OUTLINE DRAWING

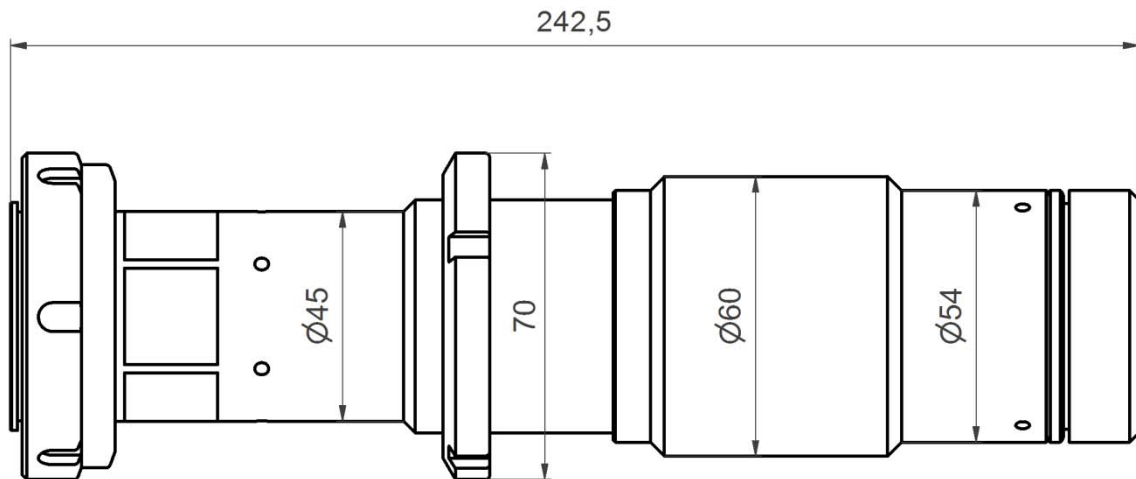

## 5 METSO PAPER PART NO

Metso Paper part no.: VAL0255774.

## 6 CONTACTS

Development, production and service:

### Dametric AB

Jägerhorns Väg 19, SE-141 75 Kungens Kurva, Sweden

Phone: +46-8 556 477 00

Telefax: +46-8 556 477 29

e-mail: [dametric@dametric.se](mailto:dametric@dametric.se)

[www.dametric.se](http://www.dametric.se)

dametric 